

TRACK

 design Prospero Rasulo

valdama

38 x 38 x h12

Lavabo in ceramica da appoggio senza troppo pieno e quattro lati smaltati. Piletta esclusa.

Countertop ceramic washbasin without overflow and four enamelled sides. Drain not included.

Colorazioni/Colours



EN 14688 - CL00

Codice/Code

Lavabo Washbasin TKL01[] A

Installazione Installation Appoggio Countertop

Troppo pieno Overflow Senza troppo pieno Without overflow

Piletta Drain Scarico libero Ø 7,2 cm Free flow Ø 7,2 cm

Dimensioni Dimensions 38 x 38 x 12h cm

Peso Weight 9,50 kg

Capienza vasca Tank capacity 7,00 Lt

Pallet 100 x 120 x 120h 20 pz.
100 x 120 x 220h 40 pz.
80 x 120 x 180h 23 pz.

Smaltatura Enamelled 4 Lati 4 Sides

Lavabo Washbasin Senza foro No tap Hole TKL01[] A

Raccomandata/Recommended
Codice/Code : PI3FCI [] A



Piletta Scarico libero in abs cromato con tappo in ceramica piatto Ø 7,2 cm.
Chromed abs Free flow drain with flat ceramic plug Ø 7,2 cm.

Accessori/Accessories
Codice/Code: PI2FACRA



Piletta Scarico libero in abs cromato con tappo cromato Ø 7,2 cm.
Chromed abs Free flow drain with chromed plug Ø 7,2 cm.

Codice/Code: SI1QOCRA



Sifone quadro in ottone cromato per lavabo
Squared chromed brass siphon for washbasin

Lavabo
Washbasin

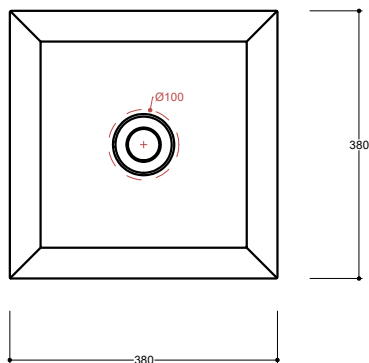
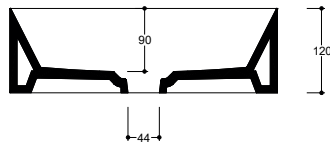

Dima di taglio

Appoggio
Countertop

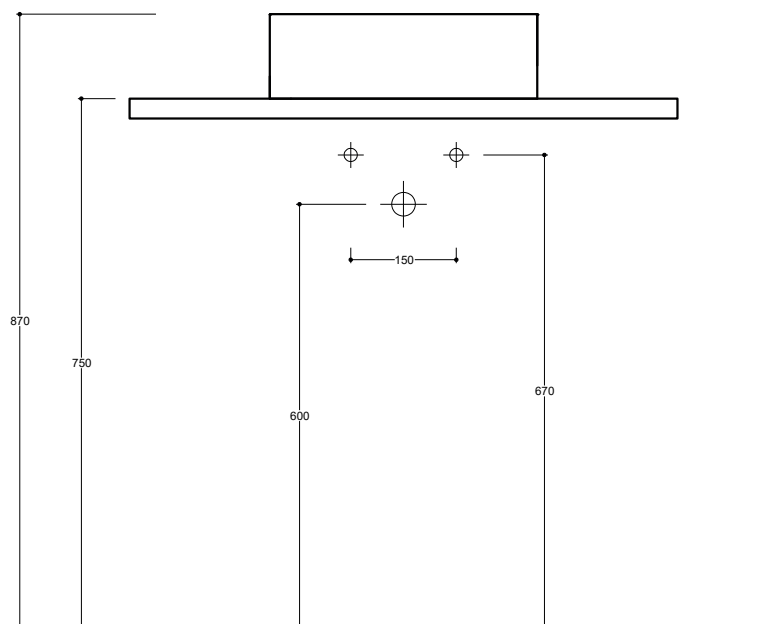

NB Le misure indicate possono subire una variazione dello 0,8 % circa, dovuta ad un'usura degli stampi o a piccole variazioni delle caratteristiche tecniche relative alle materie prime che compongono l'impasto.
NB Dimensions shown are subject to a variation of about 0,8 % , due to wear of molds or because of small changes in the technical specification of the raw materials of the dough.

ATTENZIONE le quote di installazione si riferiscono ad un impianto standard, sono generiche ed indicative. Si consiglia di adattare le quote in base alle esigenze del cliente.
ATTENTION the installation sheets refer to a standard system, they are generic and indicative. We recommend adapting the dimensions according to customer needs.

LUGLIO 2019